

**B & K Components, Ltd.**

**User Manual**

**REFERENCE 5 S2**

**Stereo Preamplifier Tuner**

USER MANUAL - REFERENCE 5 S2

© 2004 B&K Components Ltd. All rights reserved.

The information in this manual is copyright protected. No part of this manual may be copied or reproduced in any form without prior written consent from B&K Components, Ltd.

B&K Components Ltd. SHALL NOT BE LIABLE FOR OPERATIONAL, TECHNICAL OR EDITORIAL ERRORS/OMISSIONS MADE IN THIS MANUAL. The information in this manual may be subject to change without prior notice.

### **Accessories Included**

- |                    |                   |
|--------------------|-------------------|
| 1 - Reference 5 S2 | 1 - AM Antenna    |
| 1 - User Manual    | 1 - Power Cord    |
| 1 - Remote Control | 1 - Warranty Card |
| 1 - FM Antenna     |                   |



SIMPLY BETTER! is a registered trademark of B&K Components, Ltd. All other brand or product names are trademarks or registered trademarks of their respective companies or organizations.

### **Limited Warranty**

B&K Components Ltd., referred to herein as B&K, warrants your B&K equipment against all defects in material and workmanship for a period of five years from the date of purchase. This warranty applies only to the original purchaser and only to equipment in normal residential use and service. Defective equipment must be returned to B&K, prepaid, accompanied by proof of purchase and sufficient payment to cover the cost of return shipping and handling, and will be repaired or replaced at the discretion of B&K whose decision as to the method of reparation will be final.

This warranty shall not apply to any equipment which is found to have been improperly installed, incorrectly fused, misused, abused, or subjected to harmful elements, used in any way not in accordance with instructions supplied with the unit, or to have been modified, repaired or altered in any way without the expressed, written consent of B&K. This warranty does not apply to the cabinet or appearance items such as the faceplate or control buttons, nor does it cover any expenses incurred in shipping the unit to and from the manufacturer's service department.

This warranty on B&K Components, Ltd. products is NOT VALID if the products have been purchased from an unauthorized dealer or an E-tailer or if the original factory serial number has been removed, defaced or replaced in any way. B&K Components, Ltd. sells its products through authorized dealers in order to insure that consumers obtain proper dealer service and support. Buying from an authorized B&K Components, Ltd. dealer insures that you have a FACTORY WARRANTY on your B&K Components, Ltd. product. If you have any questions concerning your Factory Warranty call B&K Components, Ltd. at 716-656-0026.

Upgradability: B&K is one the first manufacturers in the audio/video industry to consistently offer software and hardware upgrades to its processing of audio signals. Through upgrades B&K delivers exceptional value to its customers. But what is "Upgradability"? Upgradability is not a guarantee; we define it as a philosophy of designing and manufacturing products so that as audio technology evolves, B&K can provide enhancements and improvements to its products that are economically viable.

THE EXPRESS FACTORY WARRANTY HEREIN CONTAINED IS IN LIEU OF ANY AND ALL OTHER WARRANTIES, EXPRESSED OR IMPLIED, INCLUDING ANY WARRANTY OF MERCHANTABILITY, UPGRADABILITY OR OF FITNESS FOR ANY PARTICULAR PURPOSE. B&K COMPONENTS, LTD. SHALL NOT UNDER ANY CIRCUMSTANCES BE LIABLE FOR DAMAGES, INCLUDING SPECIAL, INCIDENTAL, EXEMPLARY, PUNITIVE OR CONSEQUENTIAL DAMAGES ARISING OUT OF OR IN CONNECTION WITH THE PURCHASE, USE OR PERFORMANCE OF ANY B&K PRODUCT.

This warranty gives you specific legal rights. You may also have other rights which vary from State to State. Some States do not allow the exclusion or limitation of incidental or consequential damages and the foregoing exclusions may not apply to you.

No agent, representative, dealer or employee of B&K has the authority to increase or alter the obligations or terms of this warranty.

### **Returning Equipment**

No equipment may be returned to B&K Components Ltd. without a RETURN AUTHORIZATION (RA). Should you find it necessary to return equipment to B&K, for any reason, a RETURN AUTHORIZATION (RA) number must be issued by B&K in respect of the equipment being returned. You may request an RA number by calling B&K at the numbers below. We will need the following information to issue your RA number. Please have it ready before you call.

1. Your name, address, and phone number.
2. The model and serial number of the equipment being returned.
3. A description of the problem being experienced.
4. Your sales receipt.

Your call will be referred to a Technical Service Representative who will work with you to resolve the problem. If it is determined that the unit must be returned for repair, an RA number will be issued.

ACCESSORIES AND WARRANTY.....	ii
TABLE OF CONTENTS	1
SAFETY PRECAUTIONS	2
PREAMPLIFIER FEATURES	3
FRONT PANEL DESCRIPTION	4
BACK PANEL DESCRIPTION	5
SYSTEM CONNECTIONS	6
SOURCE CONNECTIONS	6
SPEAKER CONNECTIONS	7
FIVE POSITION PHOENIX CONNECTOR	8
KEYPAD or IR SENSOR CONNECTION	8
AMPLIFIER CONTROL TRIGGER	8
UNIT OPERATION	9
POWER ON/OFF	9
ON/STANDBY	9
ADJUSTING VOLUME	9
CHOOSING A SOURCE	9
ADJUSTING BALANCE	9
ADJUSTING BASS, TREBLE and LOUDNESS	10
TUNER OPERATION	10
HEADPHONE MODE	10
BKcSuite SETUP SOFTWARE	11
PRESETS	11
THE MENU SYSTEM	12
DESCRIPTIONS OF MAIN MENU SELECTIONS	12
FACTORY RESET	13
MAIN SETUP MENU FLOW DIAGRAM	14
ADVANCED MENU	15
TROUBLESHOOTING	16
ADVANCED SETUP MENU FLOW DIAGRAM	1
SPECIFICATIONS	Back



## Installation Considerations



### PLEASE READ BEFORE INSTALLING

**WARNING:** To prevent fire or shock hazard, do not expose this unit to rain or moisture. Care should be taken to prevent objects or liquid from entering the enclosure. Never handle the power cord with wet hands.

- The lightning flash with arrowhead, within an equilateral triangle, is intended to alert the user of the presence of uninsulated "dangerous voltage" within the product's enclosure that may constitute a risk of electric shock to you.
- The exclamation point within an equilateral triangle is intended to alert the user of the presence of important operating and maintenance (servicing) instructions in the literature accompanying the unit.
- Caution: To prevent the risk of electric shock, do not remove cover. No user-serviceable parts inside. Refer servicing to qualified service personnel.
- Unplug the Preamplifier Tuner from the AC outlet when plugging in or unplugging cables, when left unused for an extended period of time, when moving, or when you suspect lightning in your area.
- Prevent damage to the power cord. Do not bend, pull, place objects on, alter, etc. Replace the power cord if it becomes damaged. Always grasp the plug on the power cord when plugging in or unplugging the Preamplifier Tuner from the AC outlet.
- Your system may produce sound levels capable of causing permanent hearing loss. Do not operate for extended periods of time at high volume levels.
- Make sure the Preamplifier Tuner is placed on a level surface.
- The Preamplifier Tuner is equipped with raised feet to provide ventilation, reduce acoustic feedback, and provide protection against scratching the surface the unit is resting on. Do not remove them.
- Do not stack anything on top of the preamplifier tuner (processor, source, etc.) Leave a minimum of 2" clearance from the top of the Preamplifier Tuner to the next shelf (or component) to insure proper ventilation.
- The Preamplifier Tuner should be located away from other sources that may be sensitive to heat.
- Do not perform any internal modifications to the Preamplifier Tuner.
- Always connect the preamplifier power cord to a dedicated AC outlet for normal operation.
- If young children are present, adult supervision should be provided until the children are capable of following all rules for safe operation.
- Mistaking CONTROL OUTPUT or CONTROL INPUT connectors for audio/video inputs or outputs may damage your Preamplifier or other components.
- Damage may occur to your speakers when the power rating of the driver is exceeded while playing back music processed by the Preamplifier. Ensure that all the drivers in your system are capable of handling not only the average power being delivered by the power amplifiers, but also the peak power that is likely to be generated during strong passages. If you are unsure of your speaker's power rating, contact the speaker manufacturer or the dealer where you purchased them.
- The Preamplifier Tuner should be serviced by qualified personnel when:
  - A. The Preamplifier Tuner is not functioning properly.
  - B. The Preamplifier Tuner was exposed to rain or other type of moisture.
  - C. The Preamplifier Tuner was dropped, or the chassis is damaged.

Your new Stereo Preamplifier Tuner is a versatile audio control center. The Preamplifier Tuner is designed to sound sensational and be an attractive, easy-to-use addition to your audio system. The Reference 5 S2 makes an excellent addition to any home or office. B&K products are designed and hand assembled at the facilities in Buffalo New York, USA.

**Remote Control Operation** - Easy control of your B&K Preamplifier Tuner.

**CK1.2 Keypad Interface** - One 5-pin phoenix plug allows a CK1.2 Keypad to control the Reference 5 S2.

**Headphone Jack** - 1/4" (6.3mm) headphone jack available for private listening time.

**Front Panel Operation** - Most functions can be controlled from the Preamplifier Tuner front panel.

**Analog (RCA) Inputs/Outputs** - Six audio source inputs. One full range output. One high pass output. One low pass output (subwoofer). One summed left and right mono output. One tape loop output.

**Balanced (XLR) Full range outputs** - One pair of balanced outputs deliver the quietest and most accurate signal path between the preamplifier and amplifier.

**Gold Plated Connectors** - Better sound quality with minimized signal loss and degradation.

**Presets** - 40 user presets allow instant recall of any user setting including AM, FM or source input.

**Loudness** - May be used to add clarity to the audio signal for low to moderate listening levels.

**Bass** - May be adjusted for better room acoustics.

**Treble** - May be adjusted for better room acoustics.

**Customized Input and Present Names** - Assign names to presents, inputs, or the turn on message.

### **Internally Digitally Synthesized AM/FM Stereo Tuner**

**IR Output** - One IR output allows integrating the Preamplifier Tuner with an infrared emitter control system.

**Control I/O** - A single 5 pin plug-in Phoenix connector allows easy system access to the preamplifiers 12VDC power source, one Infrared data input signal, one RS-232 transmit for keypad status and one 12 VDC programmable trigger for amplifiers.

**BKcSuite Integration** - B&K setup software allows the user to configure and save user preferences and presets using a PC. BKcSuite software is available online at [www.bkcomp.com](http://www.bkcomp.com).

**RS-232 Controllable** - RS-232 Two Way communication allows for enhanced system control, interface with BKcSuite or an RS-232 controller.

### **Available Faceplates**

17" Black (Standard)

17" Silver (Optional)

19" Black Rack Mount (Optional)



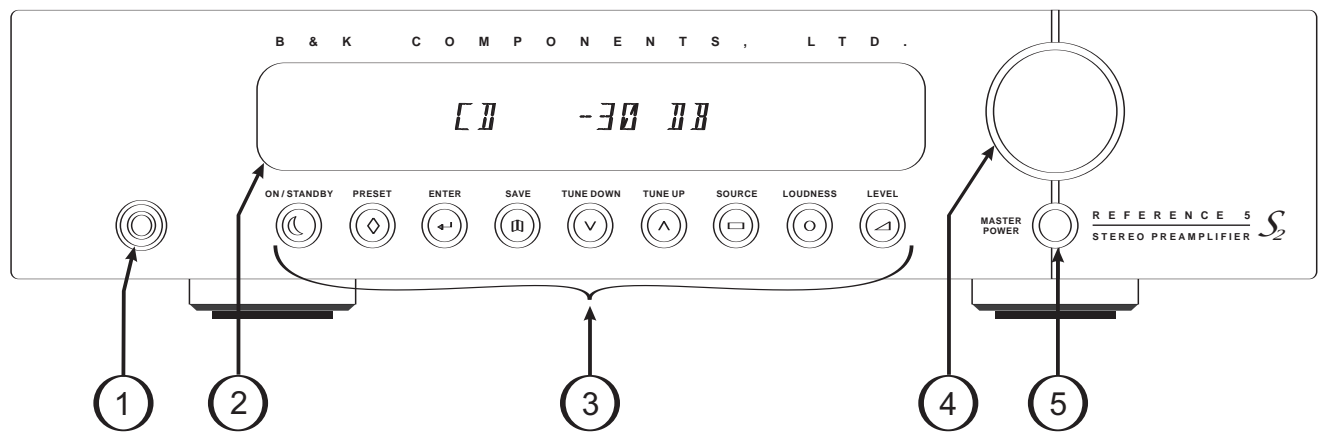





19" Silver Rack Mount (Optional)



**1. Headphone Jack** - Stereo headphones having a standard ¼" (6.3mm) stereo jack can be connected to the headphone output. The Preamplifier Tuner must be on and in HEADPHONE Mode for proper headphone operation.

**2. Front panel Display** - The Preamplifier Tuner display is a 16 character alphanumeric fluorescent display. It will display current status of the Preamplifier Tuner and any changes being performed.

**3. Front Panel Buttons** - The following table outlines front panel button operation.

 ON/STANDBY	Toggles the preamplifier in and out of standby mode, (ON or OFF).
 PRESET	Steps through audio presets for instant preset recall. Press ENTER to recall preset.
 ENTER	Confirm Selection <b>Press ENTER and PRESET simultaneously to access the menu system.</b>
 SAVE	Save a preset. Press ENTER to confirm.
 DOWN  UP	Allows radio tune - (down) or tune + (up) of the AM/FM tuner. When in menu, steps through menus, sources or characters.
 SOURCE	Steps through source inputs.
 LOUDNESS	Engages a loudness curve (high and low boosted) for low level listening.
 LEVEL	Selects VOLUME, BALANCE, BASS or TREBLE level to be adjusted via the rotational encoder knob.

**4. Volume control** - For controlling system volume. Turning the rotational encoder control clockwise increases the volume level, counterclockwise decreases the volume level. The volume knob is also used to change other Tuner and preamplifier settings when in the menu system.

**5. Master power switch** - Shuts off all power to the Preamplifier Tuner. **Normal operation of the Preamplifier Tuner requires the master power switch to remain on.** Use the ON/STANDBY button for daily ON and OFF. Only turn the Preamplifier Tuner off with the master power switch when not using it for an extended period of time.

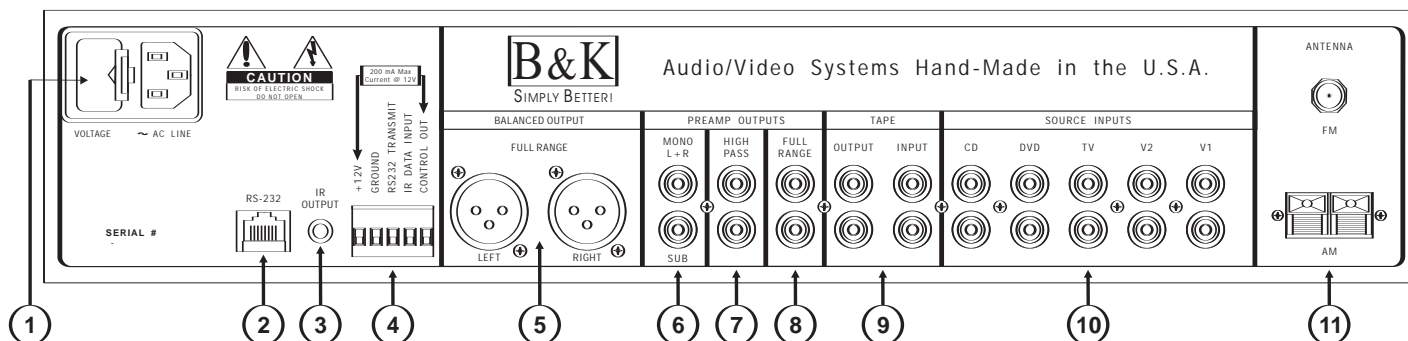

The Preamplifier Tuner's back panel is organized into groups of inputs and outputs as shown above.

- 1. AC Input Receptacle** - For attaching the supplied AC power cord to the Preamplifier Tuner. The serial number of your unit is located below the AC input receptacle. *AC line fuse rating - .5A 250V*
- 2. RS-232** - RS-232 Two Way communication allows enhanced system control and BKcSuite interface.
- 3. IR output** - IR signals received by your Preamplifier's front panel or the Infrared Data/Signal input pin are repeated out this IR connector 1/8" (3.5mm) mono.
- 4. Control I/O** - Allows connections to a zone keypad/IR sensor via a 5 pin plug-in Phoenix connector. Also supplies a control voltage for an amplifier.

+12V	- +12VDC Power to Keypad or IR Sensor
Ground	- Common Ground
RS-232 Xmit	- RS-232 One Way Transmit Out
Data In	- Infrared Data Input
CTRL Out	- 12VDC Programmable Control Out

**5. FULL RANGE Balanced (XLR) output** - Variable preamp outputs for driving an external power amplifier.

- Pin 1 - ground
- Pin 2 - POS +
- Pin 3 - NEG -

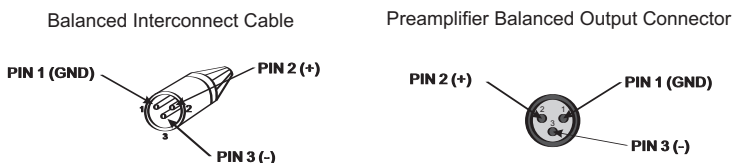

**6. MONO L+R and SUB PREAMP (RCA) outputs** - Variable level outputs for driving external power amplifiers or powered speakers. Mono is the summation of the L+R full range audio signals. It is then processed by a low-pass filter to reduce audio above 80 Hz to source the SUB output.

**7. HIGH PASS (RCA) output** - Variable preamp outputs for driving external power amplifiers or powered speakers. These outputs have been processed through a high pass filter to reduce audio below 80 Hz. Use these outputs for small speakers or in a subwoofer / satellite system. Note: these outputs are identical to the full range outputs with the addition of an 80 Hz 12 dB / Octave high-pass filter.

**8. FULL RANGE (RCA) output** - Variable preamp outputs for driving external power amplifiers.

**9. TAPE inputs and output** - Line level input and fixed output for use with an audio recorder. Tape Output supplies a return loop for the source input selected.

**10. Source line inputs** - Left and right connections from your audio sources.

Red RCA jacks	= Right analog audio
White RCA jacks	= Left analog audio

**11. Antenna inputs** - Connections for the AM and FM antennas.

## SYSTEM CONNECTIONS

It's tempting to plug in your new Preamplifier Tuner and have great sound pour out. Before you do that, take a few minutes to plan out how you want the Preamplifier Tuner to fit into your audio system. Keep the following suggestions in mind:

- List all components in your system and indicate which jacks of the Preamplifier Tuner each component will be connected to. Your Preamplifier Tuner has six sets of inputs. It is convenient to connect a DVD player to the input labeled DVD or a VCR to the input labeled V1 or TAPE, etc. However, your equipment may differ from the labeling on the back of your Preamplifier Tuner. In most cases you can connect any type of source to any input. For example, if you have a satellite receiver you can connect it to V2. You can also reprogram the source name that will appear on your Preamplifier Tuner's front panel.
- Also note the length of the cable for each component's connection and describe how it should be routed. You may want to label each cable with a name or number at both ends. Use high quality connections to maintain high quality audio.
- Think about the type and length of cable you need and obstacles in the cable's path (doorways, furniture, walkways, etc.). To decide which ones are right for you talk to your dealer about the various cable products that are available.
- For safety, keep all cables out of high traffic areas (hallways or doorways) and away from equipment that radiates power, including amplifiers, power cords, heaters, etc.
- If you might expand your audio system later, keep these ideas in mind as you plan current cable runs.
- To provide the best tuner reception, make sure the antenna is at least 6 ft away from the Preamplifier Tuner and any other equipment that may produce high frequency interference such as Personal computers, CD players, halogen lamps, etc.

## SOURCE CONNECTIONS

To connect your analog sources to your Preamplifier Tuner, take a look at the back panel. You will notice that the RCA-type audio input and output connectors are identified by colors, RED for right channel and WHITE for the left channel audio.

**Audio source Input** - To connect a source such as a CD player to the Preamplifier Tuner's analog inputs, use the analog left and right outputs from the CD player. Attach one end of the audio interconnect cable to the left (White) audio output on the CD player, then attach the other end to the left (white) CD audio input on the Preamplifier Tuner. Repeat for the right (red) audio connection. Use these same instructions for connecting to other audio sources such as a DVD, television, satellite receiver, cable box, etc.

Reference 5 S2 Source Inputs

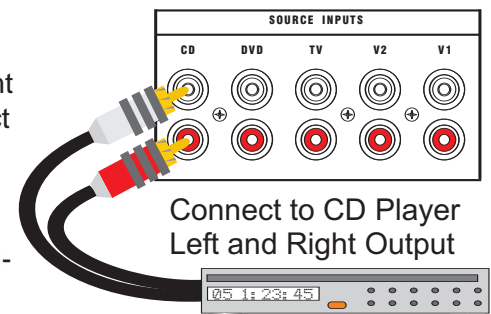

**TAPE or audio recorder** - Connect a cassette deck or other recording device to TAPE OUTPUT.

Attach one end of the audio interconnect cable to the left (white) audio input on the TAPE recorder, then attach the other end to the left (white) TAPE audio output on the Preamplifier Tuner. Repeat for the right (red) audio connection. **TAPE OUTPUT will output only the audio source selected.**

Reference 5 S2 Tape Loop

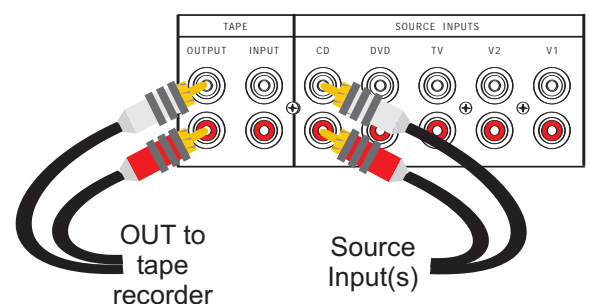



## USING FULL RANGE SPEAKERS

To connect the Preamplifier outputs to your external amplifier(s) or powered speakers use **EITHER** the balanced (XLR) connections **OR** unbalanced (RCA) connections. **Do not connect both!**

Shown below is a typical Preamplifier output setup for use with large (full range) speakers:

*Note: The use of a subwoofer is optional.*

### Balanced (XLR) Connection

### Unbalanced (RCA) Connection

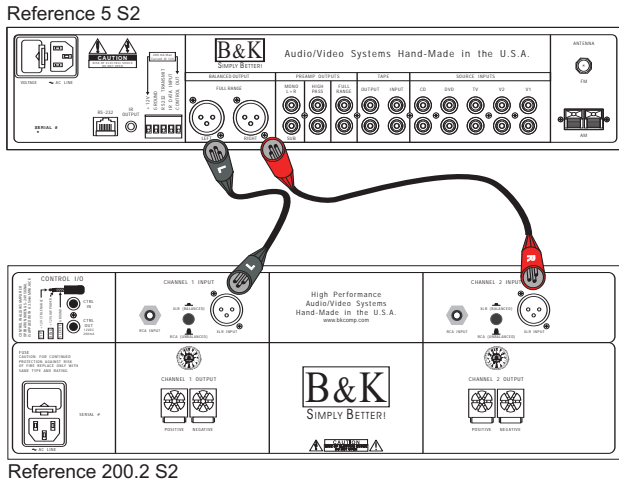

OR

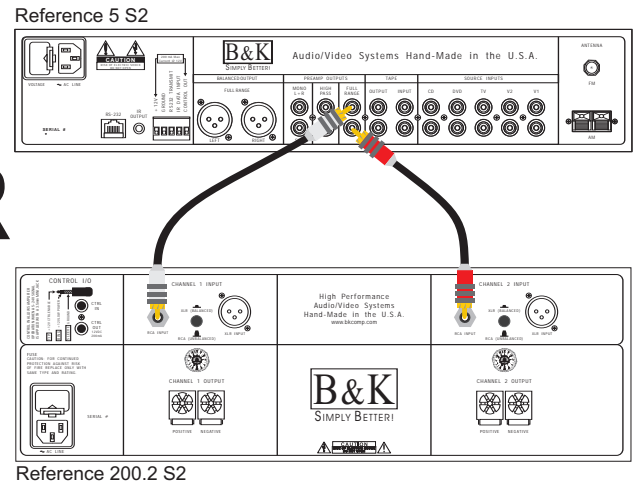

## USING SMALL SPEAKERS AND SUBWOOFER

To connect the Preamplifier outputs to your external amplifier(s) or powered speakers, use an RCA connection from the high pass outputs.

Shown below is a typical Preamplifier output setup for use with small speakers. Use the RCA connections for small speakers.

*Note: The use of a subwoofer is not optional and is needed to reproduce low frequency audio material.*

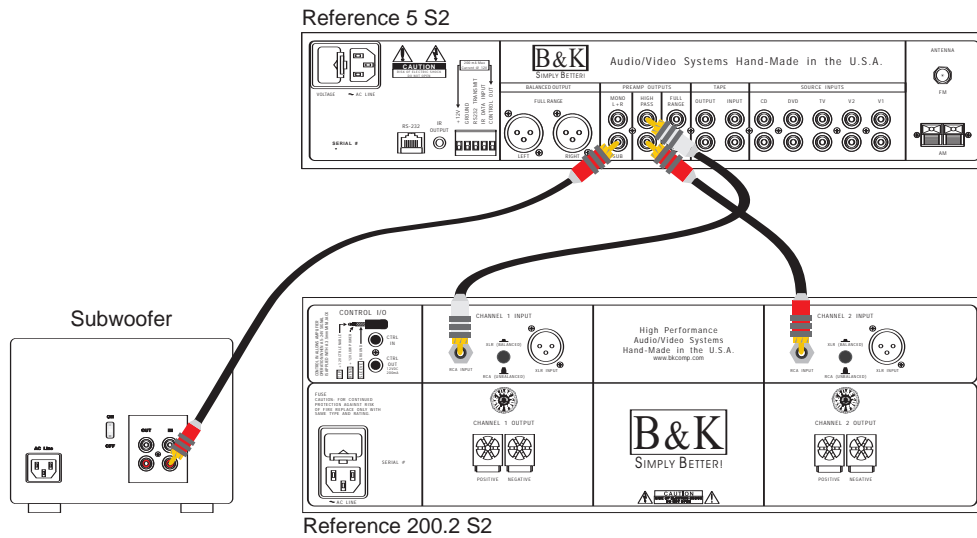

**SUB output connection** - Connect an RCA cable from the Preamplifier Tuner's SUB output. If your subwoofer does not contain its own amplifier you will need to purchase an external amplifier from B&K. Connect the Preamplifier's SUB output to the audio input of the external sub. **If you prefer to use your subwoofer's internal crossover, connect to the Preamplifier Tuner's MONO L+R output.**

## FIVE POSITION PHOENIX CONNECTOR

**Control I/O** - The five pin phoenix connector can be used when interfacing other equipment with the Reference 5 S2. Equipment such as CK1.2 Keypads, an external amplifier, or devices that require a +12VDC trigger.

- |             |                                               |
|-------------|-----------------------------------------------|
| +12VDC      | - +12VDC power supply for keypad or IR sensor |
| Ground      | - Common ground                               |
| RS-232 Xmit | - RS-232 one-way transmit out                 |
| Data In     | - Infrared Data/Signal input                  |
| CTRL Out    | - 12VDC programmable trigger out              |

**Note** - The entire control output is capable of supplying a maximum of 12VDC @ 200 mA. Check to see that the device(s) being connected to the control require 200 mA or less current.

## KEYPAD or IR SENSOR CONNECTION

To connect a CK1.2 Keypad to the Reference 5 S2, simply run a straight through CAT5 wire from the keypad location to the Reference 5 S2. The keypad end of the CAT5 can be terminated into RJ-45. The keypad end can also be terminated into the five position phoenix on the back of the keypad. Terminate the Reference 5 S2 end of the CAT5 cable manually into the phoenix connector. You can also order a RJ-45 to phoenix adaptor part number 21419 from B&K. See diagram below. If an IR sensor will be used, use the +12VDC GND and IR Data to the IR sensor. RS-232 keypad status feedback is not functional on a Reference 5 S2.

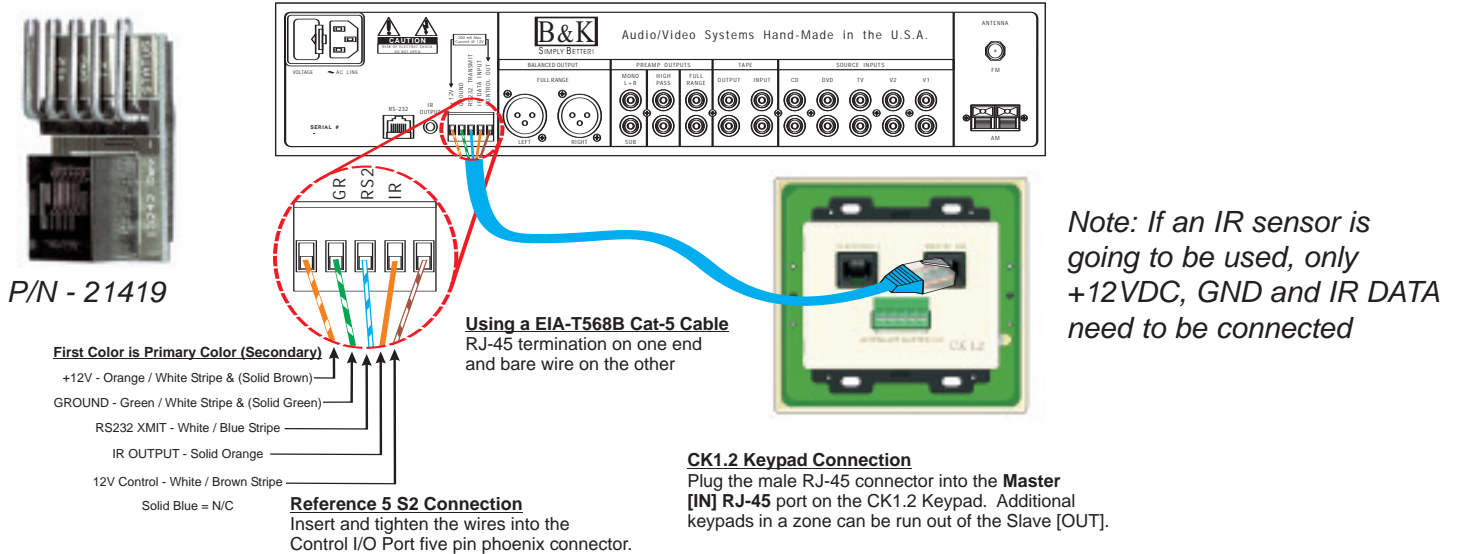

## AMPLIFIER CONTROL TRIGGER

If it is desired to use an amplifier control trigger to remotely control an external amp, then the +12VDC and GROUND should be terminated into an 1/8" (3.5mm) mono mini jack. Plug the mini jack into the amplifier Control IN that is going to be controlled. If a keypad is also connected to the Reference 5 S2, the amplifier control trigger can be connected in parallel with the control trigger. See diagram below.

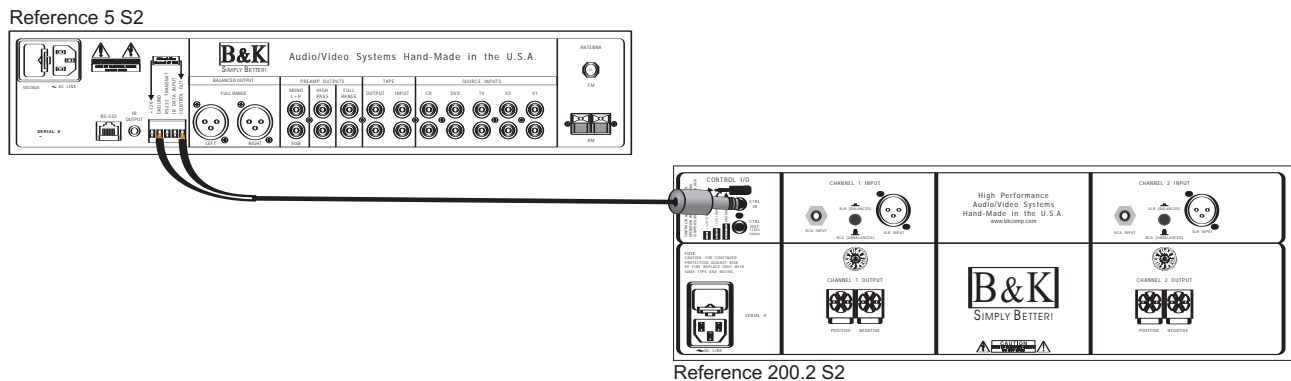

The following pages outline the normal day-to-day operation of your Preamplifier Tuner. The Reference 5 S2 can be controlled either from the supplied IR remote controller or directly from the front panel buttons.

## POWER ON/OFF

The master power switch located on the front panel of your Preamplifier Tuner must be “ON” (pressed in) for the Preamplifier Tuner to operate. When this switch is OFF (pressed out) all power is removed from your Preamplifier Tuner. This will prevent turning it back on with the remote control or keypad. For normal day to day operation, leave the master power switch in the ON position. Use the ON/STANDBY function for daily power on and off. This will allow the Preamplifier Tuner to be turned on and off from the remote control or keypad.

Whenever turning on the master power switch, you must wait approximately 10 seconds while your Preamplifier Tuner restores its internal memory and initialize system parameters. You may want to turn off the master power switch only when your Preamplifier Tuner will be idle for extended periods of time or during periods of power line fluctuations. Your Preamplifier Tuner will not lose its memory while the master power switch is off.

## ON/STANDBY

For normal day to day operation, you will put your Preamplifier Tuner in STANDBY when not in use. Standby mode keeps a bare minimum of functions running in order to allow a remote control or keypad to quickly power up the unit. Note that the front panel ON/STANDBY button is lit while your Preamplifier Tuner is in standby and is not lit when your Preamplifier Tuner is operating. The front panel alphanumeric display is off during standby. Also note that the supplied IR remote's POWER button is a toggle. The remote control or keypad additionally has discrete power OFF and ON buttons.

## ADJUSTING VOLUME

The front panel “VOLUME” control knob is known as an encoder. This is because it also has the ability to control functions other than volume. Other functions include, BASS, TREBLE, BALANCE, etc. Normally the encoder knob will control volume. Volume can also be adjusted using the remote control or a keypad. The volume can be adjusted up or down.

## CHOOSING A SOURCE



The Reference 5 S2 has the ability to select any of the eight possible source inputs. The names of the sources are default labeled for V1, V2, TV, DVD, CD, FM, AM and TAPE. These labels can be adjusted and changed using either the BKcSuite setup software or the Reference 5 S2 front panel. FM and AM cannot be changed. Even though the inputs are specifically labeled for source names, it does not matter what source is connected to each input. The label (name) of the input can be changed (See page 13 for label change procedure). A source can be selected from the remote control or a keypad if it is connected. A source can also be selected from the front panel using the source button. The source button will step through each of the source inputs.

If a recording device (such as a tape recorder) will be used to record audio material, it should be connected to the TAPE OUT RCA connectors. The TAPE OUT will output only the audio source that the user has been selected to listen to. This way an analog audio “tape” recording can be made of any device connected to the Reference 5 S2.

## ADJUSTING BALANCE

The audio balance can be adjusted left to right or visa versa using the BAL (L) or BAL (R) on the remote control. The balance adjustment will adjust the gain per each side (left or right) of the stereo output.

## ADJUSTING BASS, TREBLE AND LOUDNESS

Bass, treble and loudness can be adjusted using the remote control supplied or the front panel. To adjust the level using the front panel, press the LEVEL  button to cycle through the selections. BASS increases or decreases the low frequency content in 2 dB increments with a range of +/- 12 dB. Treble increases or decreases the high frequency content in 2 dB increments with a range of +/- 12 dB. Loudness may be used to further shape the audio signal for increased clarity and intelligibility at low listening levels. When the desired selection is displayed, rotate the encoder right or left to adjust the level up or down. The loudness can be adjusted using either the remote control or the front panel button. 

## TUNER OPERATION

All TUNER operations require the Preamplifier Tuner's source be set to TUNER.

**Manual Tuning** - press TUNE + or TUNE - on the remote control to tune the frequency UP or DOWN in single 10 kHz steps for AM or 200 kHz steps for FM. (9 kHz and 100 kHz steps for European version.) If tuning from the front panel is desired, use the UP and DOWN arrow buttons to step through the frequencies. When the tuner is selected.

**Direct Frequency Entry Tuning** - To directly recall a tuner frequency, press the TUNER button, then enter the frequency of the station. However, once *any* tuner operation (TUNER, BAND, AM, FM or TUNE+/-) is performed, you may directly enter a frequency from the remote control's numeric keypad. The Reference 5 S2 will only "look" for a direct frequency entry for three seconds after one of the tuner operation commands is received by the unit.

Example - button press steps for directly entering the radio station for 103.3 FM = FM - 1 - 0 - 3 - 3

**Seek Tuning** - Holding the remote TUNE +/- button will cause the tuner to SEEK (tune up or down automatically stopping on strong stations). Once the tuner has started seeking you can release the button. In strong signal areas the tuner may stop one step above or below the true frequency. Unless you are sure of the station's frequency, check to see that the signal might be better one step above or below the frequency that SEEK has found. In weak signal areas the tuner may continue to seek all the way to the end of the band. To stop this simply press the opposite TUNE +/- button. Seeking can also be done from the front panel by holding the UP or DOWN arrows until the tuner starts to seek.

### Remote Control Commands

**BAND** - toggles between the AM and FM frequency bands.

**AM** - selects and allows tuning of the AM frequency band.

**FM** - selects and allows tuning of the FM frequency band.

**ST/M** - allows selecting of Stereo and Mono in the FM frequency band. Setting / Programming a channel to Stereo will play the channel in stereo if it is broadcast in stereo. Setting/Programming a channel to Mono will force the channel to mono regardless of the broadcast. Use mono to reduce background noise on weak channels.

## HEADPHONE MODE

Headphone Mode allows you to operate your Preamplifier Tuner using a set of headphones. The headphone jack uses a 1/4" (6.3mm) stereo jack. To select the headphone mode, press the MODE button on the remote control. MODE will toggle between Headphone ON and Headphone OFF. When in headphone mode, the CONTROL OUT is set to off. This feature allows your Preamplifier Tuner to turn off external amplifiers or powered sub woofers with compatible 12VDC CONTROL inputs. Headphone mode can also be set up using a preset. See [page 11](#).

## BKcSuite SETUP SOFTWARE

B&K offers setup software that allows the user to completely configure the Reference 5 S2 using a personal computer (PC). BKcSuite can be downloaded from the B&K website at [www.bkcomp.com](http://www.bkcomp.com). BKcSuite provides fast and easy setup of the user presets and system settings. You can save your BKcSuite setup files as a backup. Directions on how to install the software are available online. Once the software is installed on your computer, connect a straight through CAT5 cable between the serial port of the PC to the main RJ-45 of the Reference 5 S2. Typically you will need the serial (DB-9) to RJ-45 adapter in order to establish the connection. Some laptops may require the use of a USB to serial adapter. If you wish to use the BKcSuite and you require assistance, please contact B&K customer service at 716-656-0026 M-F 8:30 - 5:30 EST.





BKcSuite

## PRESETS

Presets allow you to save your favorite settings and recall them instantly. Your Preamplifier Tuner can store forty presets. Most Preamplifier Tuner's only allow saving of tuner stations. With B&K presets, you can save the tuner station the volume, bass, treble, balance, loudness, and headphone mode. You have the option whether or not a specific volume will be recalled as well. This allows you, for example, to save a music station with enhanced bass and a talk station with enhanced treble. You are not limited to 20 AM stations and 20 FM stations. You can save 1 AM station and 39 FM stations, 1 FM and 39 AM or anything in between. Presets are not limited to Tuner stations. You can save custom settings for any source. A convenient set of 9 presets come preprogrammed with your Preamplifier Tuner.

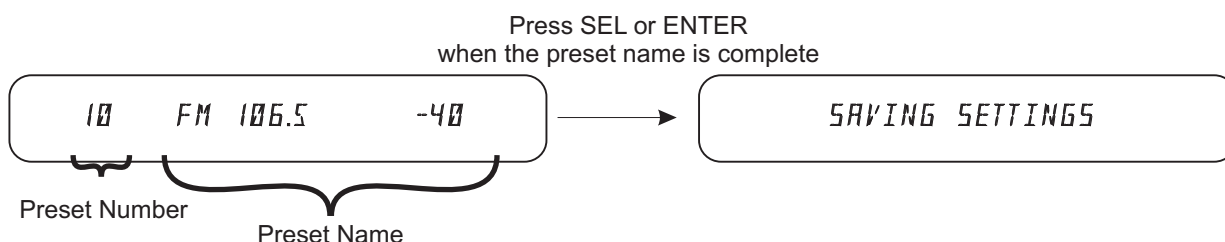
**Saving a preset (from the remote)** - To save a preset is to take a "snapshot" of the unit settings. To save a preset, first set the unit for the input or tuner station, bass, treble, volume and loudness level that is desired to be saved. Next, press the SAVE button on the remote control or the front panel. The front panel will display the two digit preset number and 11 character preset name. Since 9 presets are preprogrammed into the Reference 5 S2, preset 10 is the next empty slot. To overwrite a pre-programmed preset, simply select the preset number from the remote control once the preset number and name are displayed. The name of the preset can be adjusted by using the arrow pad on the remote control. The UP and DOWN arrows will step through the alphabet. The LEFT and RIGHT arrows will step left or right to the next character. The preset name can be a maximum of 11 characters long. Once the desired preset name has been created, press the ENTER or SEL button to confirm the setting. The front panel will display as follows:



**Recalling a Preset** - To recall a preset from the remote control, press the number of the preset desired, then press the ENTER button. From the front panel, step through the presets using the PRESET  button. The titles of the preset will display. Press the ENTER button once the preset that is desired is found. Once the enter button is pressed, the front panel will display: Recalling Preset.



## THE MENU SYSTEM

The menu system is used for adjusting the personal settings of your Reference 5 S2. The setup of your Preamplifier Tuner can be done by navigating through the menu system via the front panel or remote control. If you desire to use a PC to setup your Reference 5 S2, BKcSuite setup software can be downloaded from our website at [www.bkcomp.com/support](http://www.bkcomp.com/support). The main menu navigational flow chart diagram for the menu system is located on [page 14](#) of this manual. The following are general instructions for using the menu system through the front panel or remote control.

**MENU button** - The MENU button on the remote control will activate the menu system. Pressing simultaneously the PRESET and ENTER buttons from the front panel will also activate the menu. Once you are in the menu system, the MENU button will step you back to the next higher-level menu. If you are already at the highest level, the MENU button will exit from the menu system. From the front panel, press the PRESET and ENTER buttons simultaneously will step you back to the next higher-level menu.

**UP / DOWN ARROWS** - Once you are in the menu system, use the UP / DOWN arrows from the remote or front panel to step through the menu selections.

**SELECT (remote) or ENTER (remote or front panel)** - Some menu selections allow the next level of the menu to be accessed. Pressing SELECT or ENTER will activate the next menu level.

**LEFT / RIGHT ARROWS (remote) or Volume Knob (front panel)** - To change menu parameters, press the LEFT or RIGHT arrows to change the setting. There are no LEFT or RIGHT arrows on the front panel. Use the Volume Knob when operating the menu from the front panel. The volume knob acts as the LEFT or RIGHT arrows.

**TEXT EDITING** - Some menu selections will require you to edit text. Use the UP / DOWN arrows to change the current (blinking) character. Use the LEFT / RIGHT arrows (or Volume Knob) to move to another character position.

## DESCRIPTIONS OF MAIN MENU SELECTIONS

### HEADPHONE ON / OFF

The MAIN MENU Headphone selection activates or deactivates headphone mode. The preamplifier is default set so when the unit is in headphone mode, the 12VDC control is off, therefore turning off the external amplifier. The mode button on the remote control will also toggle headphone mode ON or OFF.

### HELP

The HELP GUIDE summarizes the basic menu operations described herein. The guide will automatically scroll through each line.

### PRODUCT-INFO

The PRODUCT INFORMATION selection that provides basic information on your Preamplifier Tuner. The information will automatically scroll through each line.

### SETUP

The SETUP selection allows the user to select from:

- Favorite Presets
- Source Names
- Source Levels
- Preset Operation
- Display Setup
- Memory Options
- Advanced Setup

### Favorite Presets

The Reference 5 S2 has the ability to store up to 40 presets. If a preset is selected as a "favorite preset", the preset (PRE) +/- button will only scroll through the presets that are set up as favorites. To set a preset as a favorite, select Favorite Presets under Setup. The UP and Down arrows cycle through presets 0-39. Right and Left toggle each preset between YES and NO. If YES, the preset is a favorite, if NO, the preset is not a favorite.

### Source Names

The source names are default labeled V1, V2, TV, DVD, CD, TAPE & TUNER. Each source name can be re-named using a maximum of 5 characters per each name. TUNER CANNOT BE RELABELED. To adjust the source names, select Source Name under Setup. Choose the source you wish to relabel by selecting the source with the remote control or by cycling through the sources using the source button on the front panel. The UP and Down arrows will step through the alphabet. Once you have completed relabeling the source input, press the MENU button to back out of the menu.

### Source Levels

Each source input can be adjusted for input gain. The available options are 0 (line level) or -6dB per input. This adjustment is useful if one source sounds louder than other sources at the same volume level. To adjust the gain, select Source Levels from the menu, select the source you wish to adjust by selecting the appropriate source input with the remote control. The sources can also be cycled through using the source button on the front panel. To adjust the gain, use the Left and Right arrows to toggle between 0 or -6dB. Once you have completed the adjustment, press the MENU button to back out of the menu.

### Preset Operation

In the preset operation selection, you are able to adjust how your presets are recalled. You have the ability to select preset volume recall and preset auto naming. If you desire the volume level to be recalled when a preset is recalled, set this selection to PRESET. Otherwise when set to CURRENT, the volume will stay at the current level when the preset is recalled. When a preset is created, auto-naming will generate a generic name for the preset. The generic name will use the source input label and the volume level. If you wish to customize the name of your presets, select NO for Auto Naming.

### Display Setup

Display setup describes the brightness of the front panel display. The options are BRIGHT, MED, and DIM.

### Memory Options

Memory options allows you to back up all the customized settings you have made to the Reference 5 S2. The options in this selection are BACKUP and RESTORE. Even if a backup is not made, the customized settings will not be lost during normal day to day power on and off. It is a good idea to create a backup once all the settings have been set. These settings are then stored on an internal EEPROM. Select RESTORE, if you desire to recall the memory backup at any time.

**Note: A Factory Reset will erase the memory backup.**

### Advanced Setup

The advanced menu is described on [page 15](#) of this manual.

## FACTORY RESET

Sometimes a factory reset is necessary in order to clear problematic symptoms sometimes experienced in the field. A factory reset will clear all system settings, and all presets. A factory reset will also clear any information backed up onto the EEPROM that may have been accomplished by a Memory Backup.

**To perform a Factory Reset On a Reference 5 S2,  
Simultaneously press and release the ON/STANDBY, DOWN and LEVEL buttons.**

Once you see "Format Filesys" on the front panel you can release the buttons. A reset will take approximately 60 seconds to execute.

REFERENCE 5 S2 MAIN MENU FLOW DIAGRAM

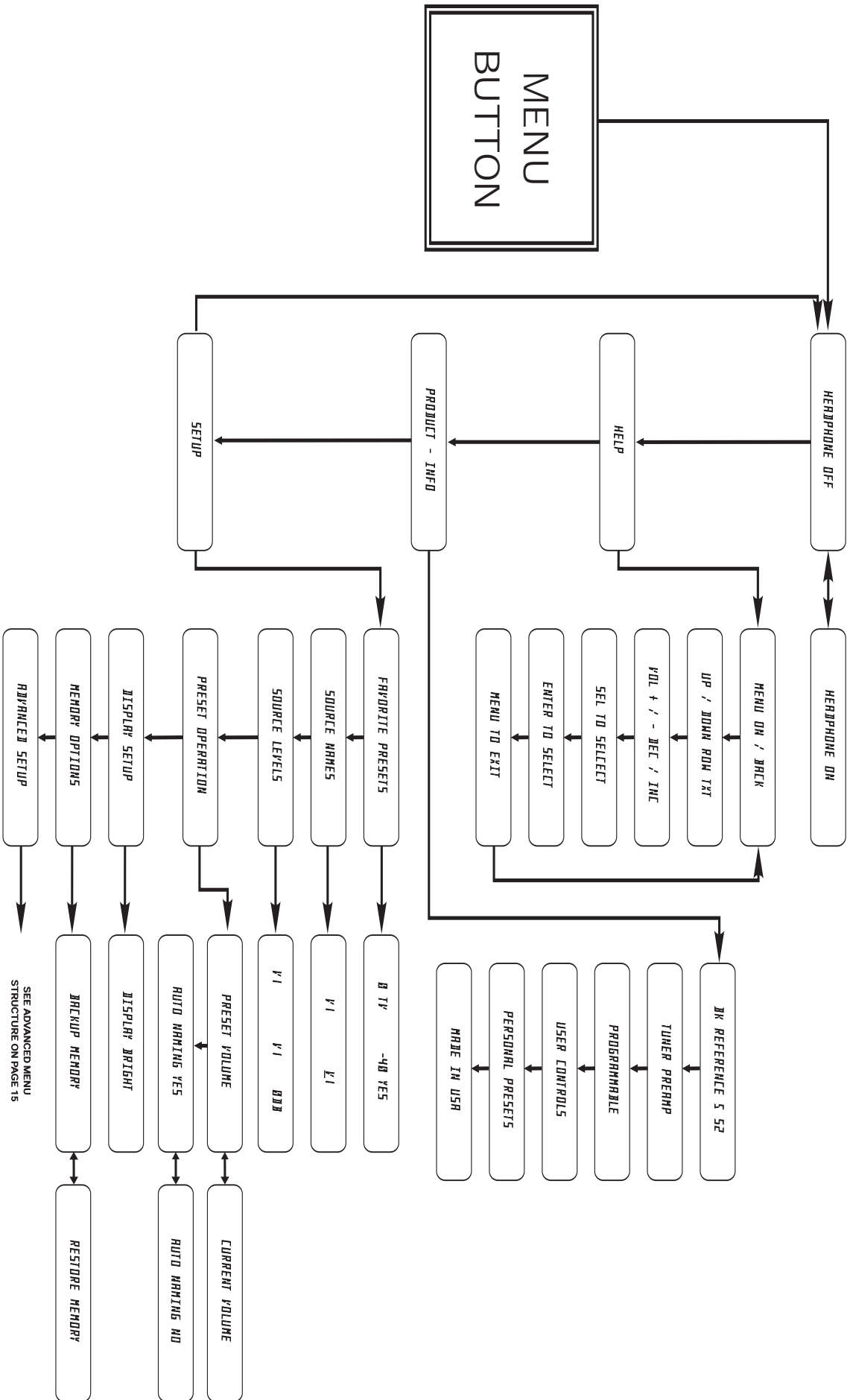



## ADVANCED MENU DESCRIPTIONS

The advanced setup menu allows the user to adjust the following features. An advanced menu navigational flow chart is located on [page 17](#) of this manual.

- Maximum volume level.
- IR code-set the unit will operate on.
- Power on titles.
- +12VDC control trigger output.
- User Security
- RS-232 port.

**From the factory, the advanced menu is hidden from user access. To un-hide the advanced menu, simultaneously press the UP, DOWN and ON/STANDBY buttons.** “ADVANCED VISIBLE” will flash on the screen indicating the advanced menu is unhidden. If the memory or front panel has been locked, this button press sequence will unlock the memory.

### Maximum Volume Level

The maximum volume level can be limited on the Reference 5 S2. The absolute maximum volume level is +8dB. Line level volume level is 0dB (zero).

### Product ID (Code-Set)

The product ID (IR code set) can be adjusted if operation with other B&K gear is required. The default ID is 002 (zero zero two). The Reference 5 S2 can be assigned to any ID (B&K code-set) between 001 and 016. This allows sixteen different Reference 5 S2's to operate independently using different remote controls. This feature is typically useful if multiple Reference 5 S2's are used in the same system (whole house audio systems). **NOTE:** If the code set of the preamplifier is changed, you will need a learning or programmable remote control to operate the unit via IR. B&K offers the SR10.1 programming remote, the CK1.2 Keypad or MZ-128 remote if different code-set operation is required. For more information on code-sets, see the [B&K CT610/310/600 Mult-Zone Receiver User Manual](#).

### Power On Titles

When the Reference 5 S2 powers up it will flash two lines of power on titles. These lines can be customized for your own preferences. Each line for power on titles contains 16 customizable characters.

### Control Setup (+12VDC trigger)

The single +12VDC control trigger can be programmed to be on or off depending on the different situations the Preamplifier Tuner is used for. The control trigger can be setup for each input of the Reference 5 S2. Each input has the following options:

OFF	= When the input is selected, the control output is off.
ON	= When the input is selected, the control output is on.
PHONES	= (Headphones) When the input is selected and headphone mode is selected, the control will turn off, therefore turning off an external amplifier.
REMOTE	= When the input is selected, IR will pass-through the 12VDC control out. IR will pass-through either from a keypad/IR sensor or the front panel. The emitter can be connected to the +12VDC output and the common ground.
RS-232	= When the input is selected, the control output can be controlled with RS-232.

Typically, the +12VDC trigger will be used for controlling an external amplifier. When the 12 volts is on, the amp is on, when the 12 volts is off, the amp is off. The amplifier must be equipped with a control trigger. All B&K amps are equipped with control triggers. The Preamplifier has the 12VDC trigger default set for headphone on all inputs. The control will remain on during normal listening (amp on), when headphone mode is selected, the 12VDC control is off (amp off).

## Security

The Reference 5 S2 has the capability to lock the front panel buttons, turn off the front panel IR receiver, and lock the memory so it cannot be changed. If the front panel IR receiver is turned off, it will also disable a keypad or IR sensor if a keypad or IR sensor is being used.

<u>Selection</u>	<u>Options</u>	<u>Definitions</u>
Memory Lock	- YES or NO	= Locks all personal settings from being changed.
Front Lock	- YES or NO	= Locks all front panel operation.
IR Lock	- YES or NO	= Disables all IR communication to the preamplifier

## RS-232

The main RJ-45 jack can be enabled or disabled. The baud rate can be adjusted. For best operation the baud rate should be left at 9600. The Echo/Update feature can be toggled on or off. Echo and Update will either echo an RS-232 message received or send out an update message indicating the unit has made a change. The transmit and receive ID's can be adjusted for operating with RS-232 controllers. B&K provides all RS-232 serial codes for use with RS-232 controllers. These documents in .pdf format can be found on our website at [www.bkcomp.com/support](http://www.bkcomp.com/support).

## TROUBLESHOOTING

<u>PROBLEM</u>	<u>POSSIBLE CAUSE</u>	<u>POSSIBLE SOLUTION</u>
No sound Display will not light.	<ol style="list-style-type: none"> <li>1. Power cord not plugged in.</li> <li>2. Power off at AC source.</li> <li>3. AC power inlet fuse blown or faulty. Power switch in off position (out).</li> <li>4. Blown line fuse.</li> </ol>	<ol style="list-style-type: none"> <li>1. Reconnect power cord.</li> <li>2. Check AC switch or fuse.</li> <li>3. Push in power switch.</li> <li>4. Replace line fuse with .5A 250V Fast Blow fuse.</li> </ol>
No sound Display on.	<ol style="list-style-type: none"> <li>1. Preamplifier is in mute.</li> <li>2.</li> </ol>	

**Note: If Preamplifier continues to blow fuses DO NOT REPLACE WITH HIGHER VALUE!. Contact B&K customer service.**

REFERENCE 5 S2 ADVANCED MENU FLOW DIAGRAM

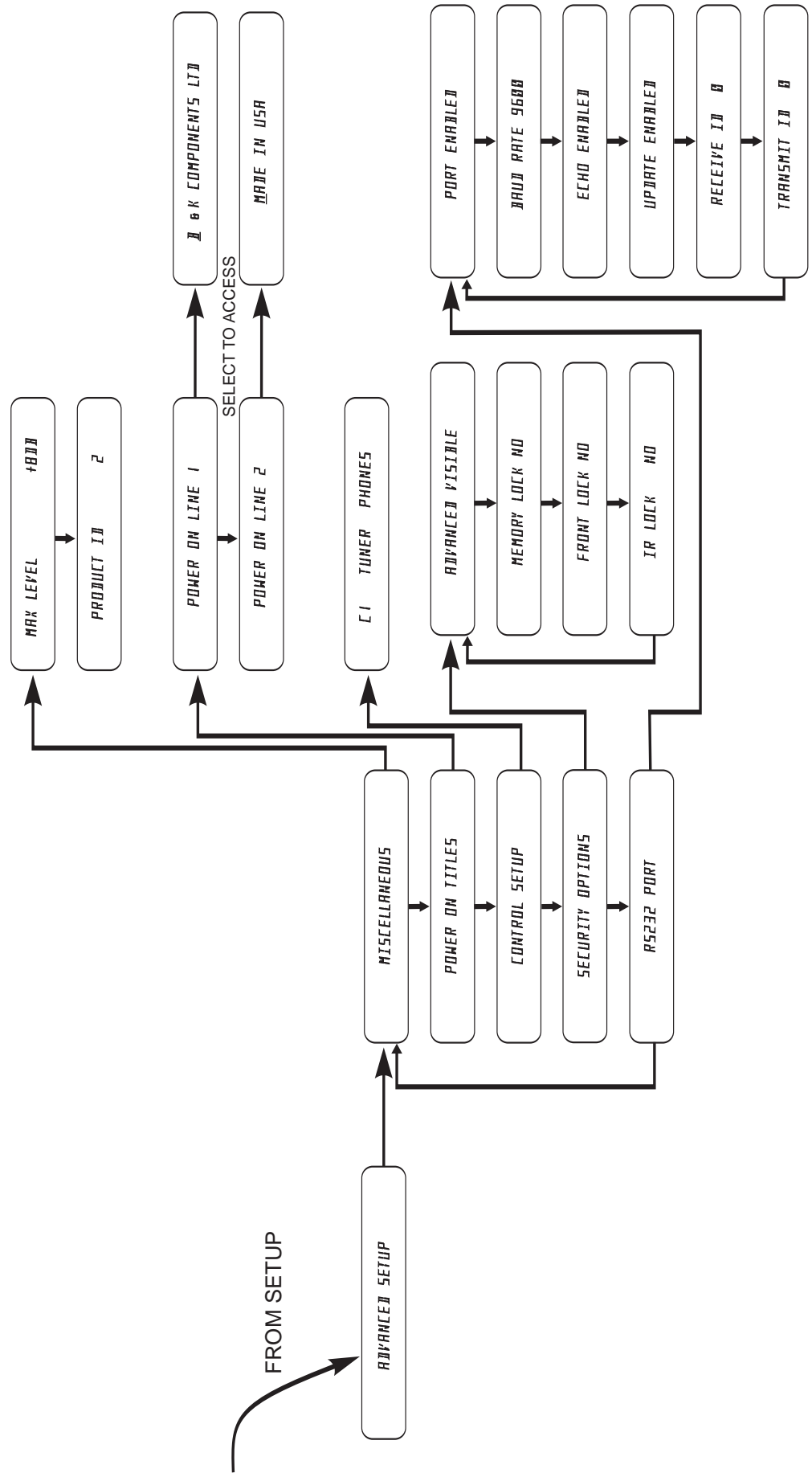

# SPECIFICATIONS

## REFERENCE 5 S2 STEREO PREAMPLIFIER TUNER

Frequency Response	5 - 45kHz	
Input Sensitivity	63 mV	
Signal to Noise Ratio	89 dB	
Input Impedance	50 K $\Omega$	
Output Impedance	221 $\Omega$	
Maximum Output Level	8V	
<b>Tuner Specifications</b>	<b>FM</b>	<b>AM</b>
Frequency Range	87.5 - 107.9 MHz	520 - 1670 kHz
Total harmonic Distortion	Less than .25%	Less than .3%
Frequency Response	20 - 15 kHz	20 - 15 kHz
Alternate Channel Selectivity	65 dB	30 dB
Signal to Noise Ratio	70 dB	70 dB
Antenna Input Impedance	75 $\Omega$	300 $\Omega$
IHF (Usable) Sensitivity	12dBf	28 dBf
Capture Ratio	2 dB	-
Mono / Stereo Sensitivity	15 / 35 dBf	-
User Presets	40	
High Pass / Low Pass Crossover (RCA output)	80 Hz non-adjustable	
Full Range output (RCA)	Yes	
Keypad or IR sensor connections	Yes	
Unbalanced (RCA) audio inputs	6	
Balanced (XLR) outputs	1 full range pair	
Tape loop output	1	
RS-232 Controllable	Yes	
IR output (pass-through)	5V	
AC Line Voltage	120 / 220 / 240 VAC (optional / switchable)	
Control Output	10 - 12VDC @ 200mA	
Dimensions in Inches (Cutout Dimensions)	Width	17.00 (17.12)
	Height	3.83 (3.95)
	Depth	9.50 (10.62)
Shipping Weight	16 lbs	
Power Consumption	30 watts maximum	
Replacement Fuses	AC Line - .5 Amp / 250 Volt Fast Blow	

\*Specifications subject to change without notice